

## AUTOMATIC BOOM GATE BARRIER

### FG-D1500L

6M TELESCOPIC ARM  
WITH SAFETY RUBBER

[www.felixsecuritysystems.com](http://www.felixsecuritysystems.com)



# Features

- Direction is adjustable.
- **Auto bounce back function:** Built-in sensor can detect when arm hits obstacle.
- **Intelligent limited sensor:** Limited sensor can check open & close position automatically. No need to adjust by hand.
- **Position memory function:** The motor can remember limited position so it moves back to correct position even we turn the motor handle to avoid motor stuck.
- Work under low temperature. No thermal protection required.
- **Long working life:** It can open and close 3 million times.

## SPECIFICATIONS

MODEL	FG-D1500L
Arm	6m telescopic arm with Safety Rubber
Color	Black box with Yellow door / Silver Door
Maximum straight boom length	6 meter
Opening and closing times	6sec - 6m
Voltage & Frequency	220VAC - 240VAC / 50Hz
LED Indicators	Top (Green when Open) & Bottom (Red when Closed)
Motor power consumption	60W
Remote control frequency	430.5MHz
Maximum remote control distance	≤30m
Working temperature	-30°C to 80°C
Humidity	≤95%
IP Rating	IP54
Drive	Torque motor
The height of boom support	890mm
Input interface	+12V relay signal or ≥100MS pulse signal
Housing dimension	355*245*1035mm
Weight (Without barrier boom)	39Kgs

## DIMENSIONS

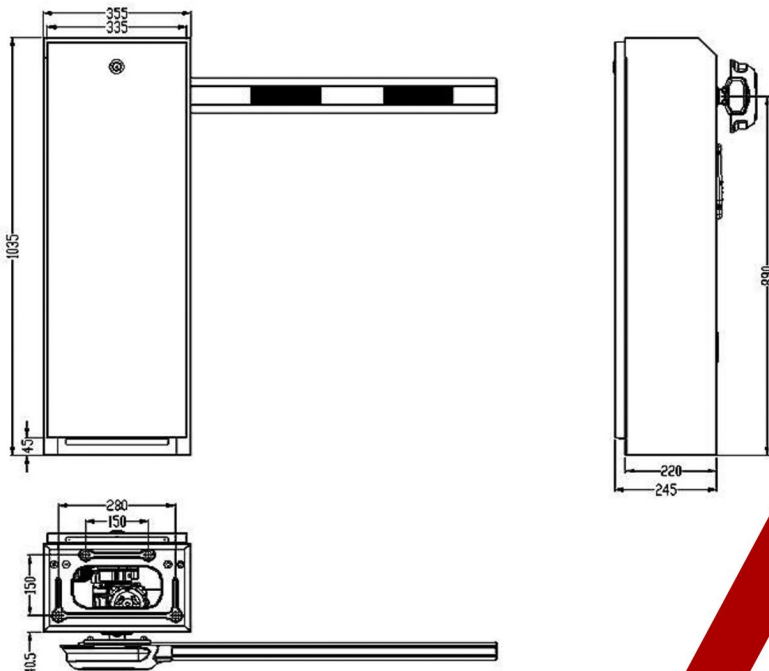

Left-Hand Version

Right-Hand Version



## BOOM TYPE

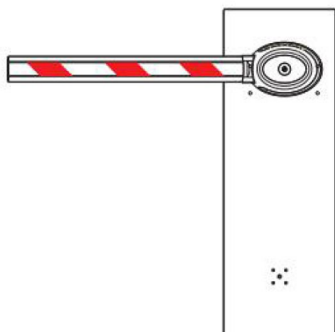

4.5m Telescopic arm

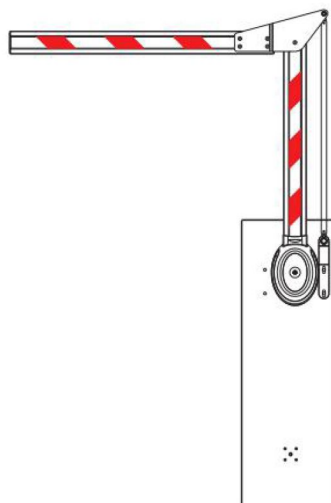

90° Folding arm

### MECHANICAL FEATURES

- Integrative machine core.
- Accurate link mechanism.
- The motor handle can turn to lock or open the boom when power goes off.
- 60W turbine worm transmission deceleration induction motor can
  - Saves energy.
  - Avoid overheating.
  - Works 24 hours non-stop.
  - Drive steady.
  - Low noise.
  - Structures compact.
  - Release the self-lock.

### ELECTRICAL FEATURES

- High integration level and powerful functionality.
- Shut down functions (The motor will be shut down automatically after 6 seconds) and thermal protection functions will effectively protect the motor.
- High quality power relay to ensure power stability and photoelectric isolated protection circuit to ensure signal stability.
- Integration of the wireless remote control receiving module to ensure the stability of the wireless control.
- The quench circuit to ensure main board working life.
- High efficiency magnetic core transformer to ensure machine operation in damping situation.
- Support both hall-limited sensors and angle-limited sensor.
- The angle-limited sensor has auto bounce back function and auto adjust limited position function.
- Auto close function (Configuration 10 seconds).
- Close loop bounce back function: The function board will not receive loop single when the arm angle is less than setting value.

### SAFETY FUNCTIONS

**Pressure sensor anti-crash functions:** If the boom meets anything during closing process, the boom will open automatically.

**Loop detector anti-crash functions:** If car is under the boom, the barrier gates will not be close, and it will close automatically when the car passes the boom.

**Open first functions:** No matter the boom locates in any position, it will open if barrier gate receives open signal.

**Plastic strips:** To avoid accidental damage, Plastic strips can be installed on the boom.

## Retractable Straight Boom

$A = \text{Master Boom}$ ,  $B = \text{Slave Boom}$  ( $B \leq A$ )

Part B can be contracting inside part A. This boom design is provided for easy transportation. 3m boom transportation will be easy and more convenient. 6m telescopic boom will be made as 3m and 3m.

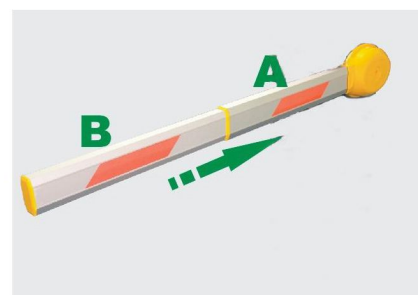

## CORE STRUCTURE

Use gear drive mechanism and bearing turning mechanism to control the boom movement, and angle sensor can accurately control boom's vertical position and horizontal position.

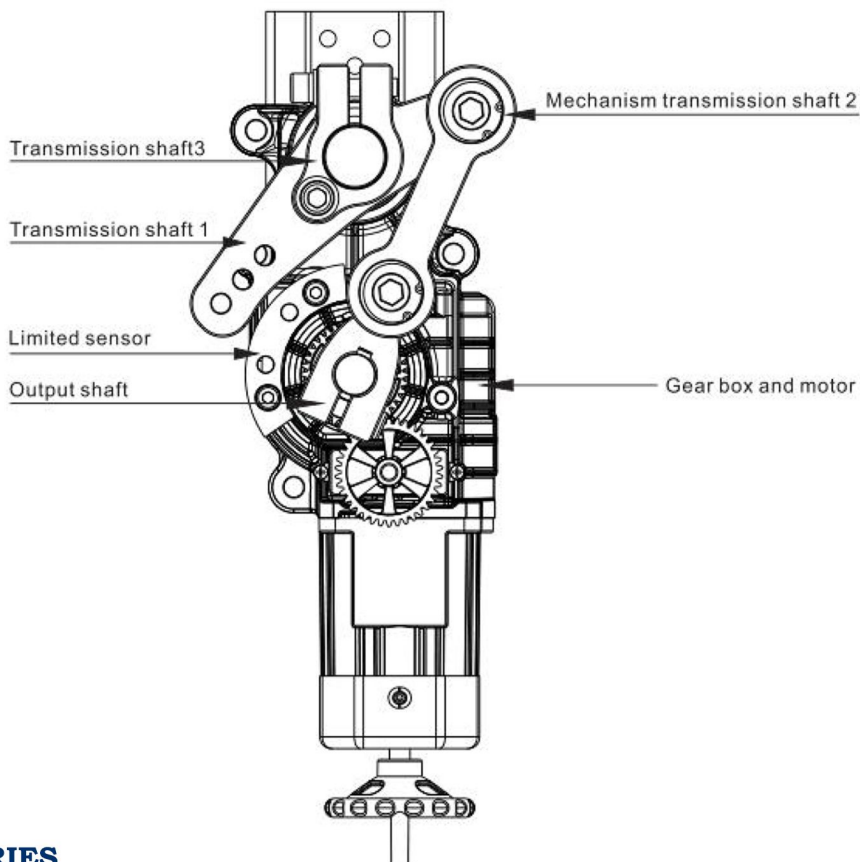

## OPTIONAL ACCESSORIES



**F-STD:** Arm Stand

