

545 Series



Double Electromagnetic Lock 1200

Model ULC545-D-A (Unmonitored Version)
ULC545-DL-A (Monitored Version)

DESCRIPTION

Double EM locks 1200 were designed to meet fire/life safety applications by providing an auxiliary locking mechanism that has no moving parts to bind or wear out for trouble free operation. This will ensure inhibited release at all times where they have become extremely prevalent in applications other than fire/life safety. Suitable for access controlled & secure areas within buildings with double leaf doors.



FEATURES & SPECIFICATION



Life Safety Applications



Zero Residual Magnetism



Low Energy Consumption



Cost Savings

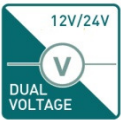

12/24Vdc Selectable



Ideal for all door types

Models	ULC545-D-A	ULC545-DL-A
Features & Spec.		
Lock Status Monitoring	-	✓
Holding Force	Up to 1200lbs x2	
Magnet Size	532 X 67 X 40 mm	
Armature Size	185 X 61 X 16.5 mm	
Current Drain	420mA±10%/12Vdc 210mA±10%/24Vdc	
Operating Temperature	(-10 to 55)°C (14 to 131)°F	
Housing Finishing	Anodized Aluminium	
Est. Weight	9.3kg	

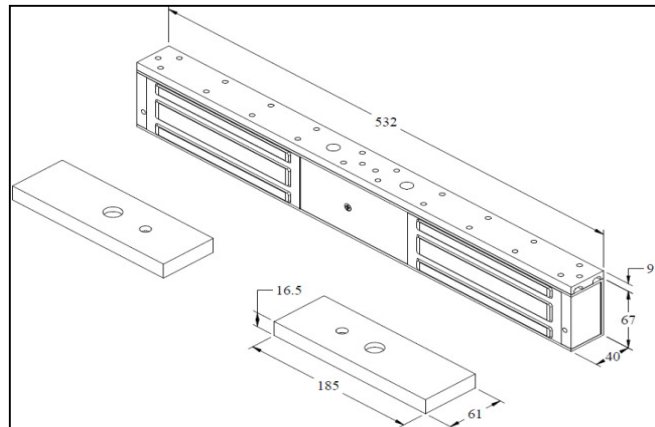

545 Series



Double Electromagnetic Lock 1200

STANDARD INSTALLATION DIAGRAM

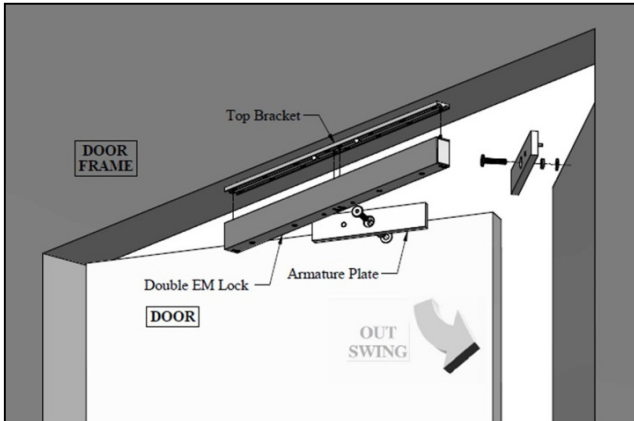

Explode View

WIRING DIAGRAM

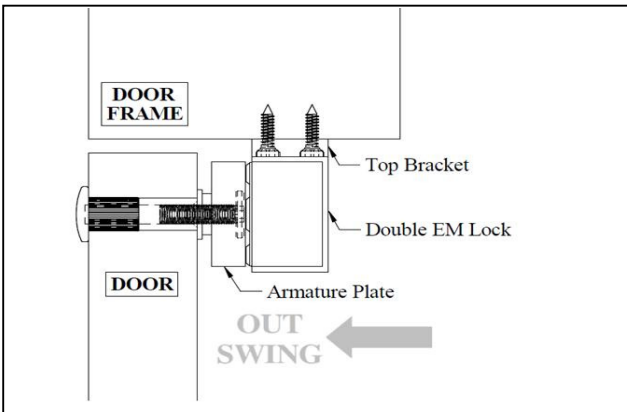
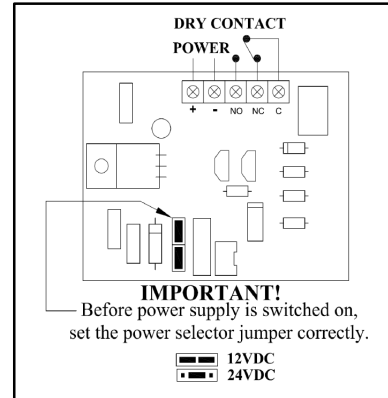

Side View

OPTIONAL - BRACKET SELECTION

LS-545	U1-545	ZL-545	ZLE-545	LSDC-545-G	ZLDC-545-G
AH-545	AB-545				



GWXT
UL10B
UL10C

Fire Test of Door Assemblies.
Positive Pressure Fire Tests of Door Assemblies.



FWAX2
UL294
NFPA 101

Access Control System Units.
Life Safety Code.

www.algateclocks.com

WARRANTY: -ALGATEC EM Lock are warranted against defects in material and workmanship while used in normal service for a period of 5 years from the date of sale to the original customer.
DISCLAIMER: -Specifications are subject to change without prior notice. -Attached photo is for reference purpose only, actual product may varies.