



Overview

EL-DH-602 is a standard type wall mount door holder which adopts low power consumption that makes it more environments friendly and more durable. Professional anti-residual magnetism design ensures highest security. It will release automatically the fire door when fire alarm. It also contains build-out release button for testing and build-in MOV which reverse current protection.

Specification

Product Parameter	Parameter Description
Dimensions	L80 x W80 x H105 (mm)
Holding Force	50kg (110Lbs)
Voltage	12/24 VDC +/- 10% (Adjustable)
Current Draw	12V/140mA 24V/70mA
Suitable for	All kind of Single & Double Smokeproof Doors
Surface Temp	≤+20°C
Operating Temp	-10~+55°C(14-131F)
Suitable Humidity	0~90%(relative humidity)
Finishes for Shell	High Temperature Paint and Environmental Protection Zinc
Finishes for Armature	Zinc
Weight	1.0kg

Dimensions

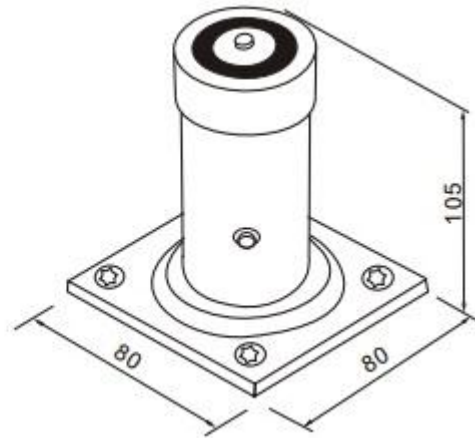
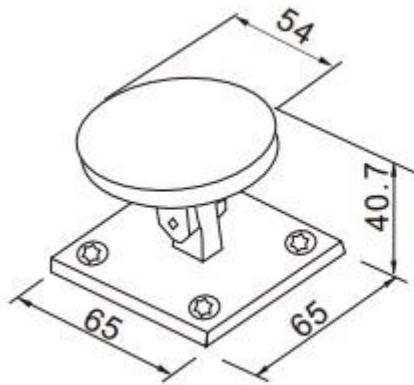

Installation

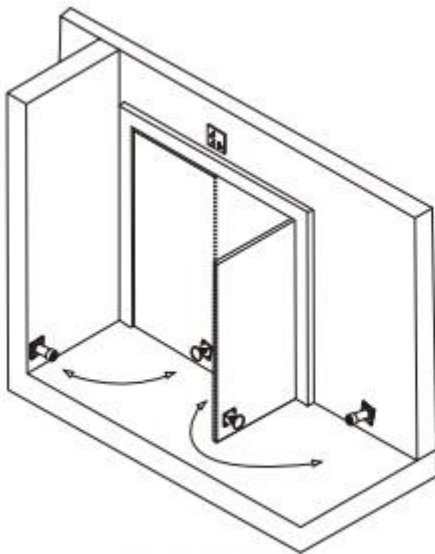

Installation

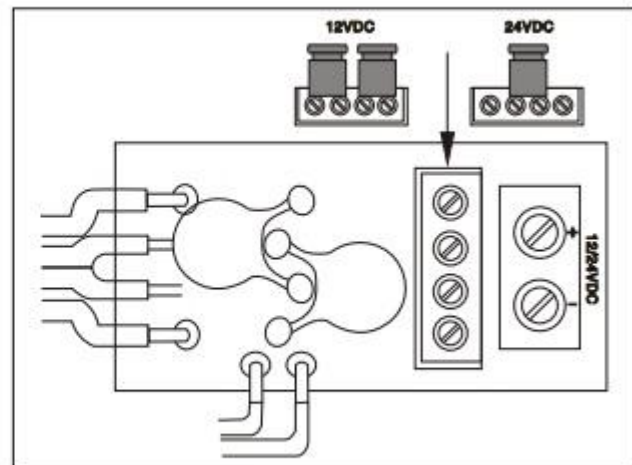

Wiring Instructions